



## Blind Corner Base Cabinet

Assembly Instructions for 1 Drawer, 1 Door Frameless Blind Corner Base Cabinets  
(For 39", 42", and 45" Blind Corner Base Cabinets)

### BEFORE YOU START

**STEP 1:** Collect your tools. For this project you will need:

- Phillips head Power Drill
- Common/Flathead screwdriver
- Wood glue
- Nail gun or Staple gun
- Rubber mallet
- Box cutter

**STEP 2:** Place the box on a sturdy work surface.

**STEP 3:** Open the box by carefully cutting the tape on the ends of the box. Lift the box from the contents on one side when cutting along the center seam of tape to avoid damaging the pieces.

**STEP 4:** Pull back the packaging and carefully lift each piece out of the box, inspecting them for damage. Place them against a wall.

**STEP 5:** Remove the box of hardware from the packaging. Separate the types of hardware into small piles and place them in a plastic box.

**PRO TIP:** Hardware can get lost, placing it in a box can keep it organized, easy to reach, and prevent small pieces from getting misplaced.

**STEP 6:** Locate your model number on the website and click the Packing List link to open a PDF version of the exploded view Packing List, print. Make sure all parts are accounted for, checking them off the part list.

### BEGINNING ASSEMBLY

#### CABINET BASE

These cabinets are designed to be interchangeable; meaning that the drawer/door side and the blind side can be switched depending upon your needs. Decide which side you need for the blind section of the cabinet and which you need for the drawers and door then proceed to STEP 1 of the assembly.

**STEP 1:** Take the drawer side (Part A) and lay it flat on your work surface with the interior side facing up.

**\*NOTE:** If you want your drawers on the left side of the cabinet as you face it, select the left side Part A. If you want the drawers on the right side of the cabinet, select the right side Part A.

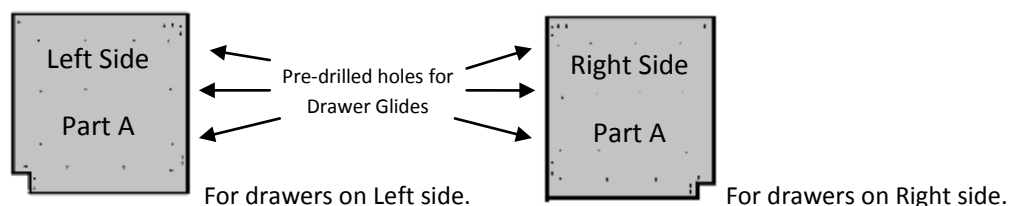



**STEP 2:** Locate the Drawer Slides and remove them from any packaging. Fully extend each slide. The furthest segment of each slide is the Drawer Box Segment. Pressing the black plastic pin of the Drawer Box Segment upward, pull it from the remaining segments of the Drawer Slide and place it aside for later.

**STEP 3:** Place the flat side of the remaining Drawer Slide on Part A, aligning it with the pre-drilled holes ensuring that the slide extends to the front of the cabinet. To get access to the drill holes, you will need to slide the inner track until the holes are visible. Using the 12mm Slide Screws, gently screw the drawer slides to Part A. Repeat as needed.

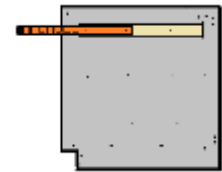

**NOTE:** You will only install one Drawer Slide on this section of Part A. Save the remaining slide for Part J.

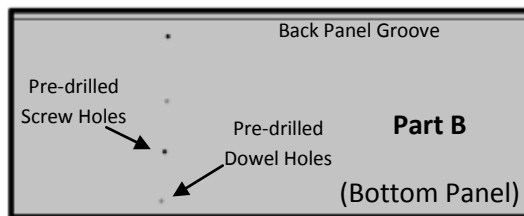

**STEP 4:** Locate Part B (Bottom Panel). As an interchangeable model, find the side of Part B that correlates with your drawer base. For example, a cabinet with the drawers on the left (as you face it) will have pre-drilled holes on the middle left section in order to meet Part M (Center Stile Bottom) and Part O (Center Stile Bottom Side).

**STEP 5:** With the Drawer Slides attached to Part A, attach Part A to Part B (Bottom Panel) fitting wood dowels into the dowel holes. Secure Part A to Part B using four 50mm screws and ensure that the groove at the back of Part A meets the groove on Part B.

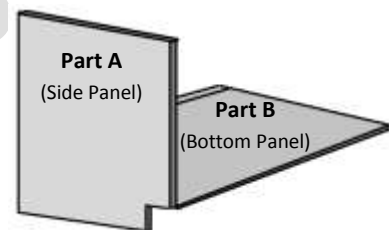

**NOTE:** The grooves must align as they serve as the track to slide in the back panel later in the assembly process.

**STEP 6:** Once Part A is attached to Part B, attach the other side of Part A to Part B and lay the unit on its back.

**PRO TIP:** Many assemblers use wood glue to secure the dowels and create added strength. Any excess wood glue can be removed with a damp towel.

**STEP 7:** Locate Part L (Toe Kick) and fit it between the two Part As, aligning the pre-drilled screw holes. Using four 50mm screws, secure the toe kick to Part A (Left) and Part A (Right).

**STEP 8:** Set the unit aside.

**STEP 9:** Locate Part J (Center Divider) and place it flat on your work surface. If you chose a left side drawer orientation, attach the remaining Drawer Slides to Pre-drilled Drawer Slide holes on the left side of Part J. If you chose a right side drawer orientation, attach slides to the right side of Part J as described in STEP 3.

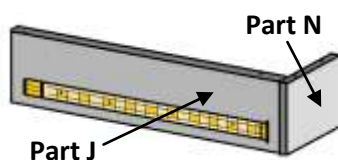
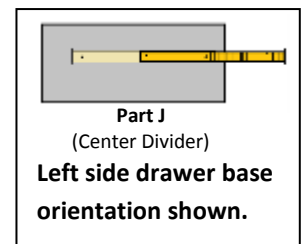

**STEP 10:** Locate Part N (Center Stile Top). Add a dab of wood glue to the dowel holes and connect Part J (Center Divider) to Part N (Center Stile Top) using wood dowels. Set aside.

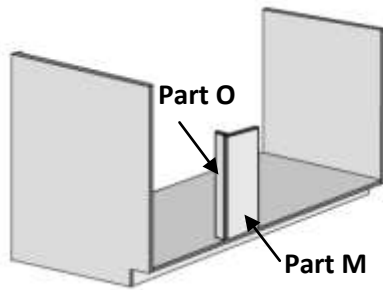

**STEP 11:** Locate Part M (Center Stile Bottom) and Part O (Center Stile Bottom Side). Apply a small dab of glue to the dowel holes and attach Part O to Part M using the provided wood dowels. Placing a dab of wood glue in the dowel holes, fit the joined pieces (Part M and Part O) to Part B (Bottom Panel) using wood dowels.

**NOTE:** When using wood glue to secure dowels, remember to also add a bead of glue to their corresponding holes in Part A and Part B. *Remember – what you do on one side, do on the other.*

**STEP 12:** Locate the two Part Is (Top Front Connecting Beams). One of the Part Is is a support bridge between Part M and Part N and the other serves as a support bridge at the top of the cabinet. Using 50mm screws, secure one of the Part Is between the two Part As and on top of Part M. Set the other Part I aside.

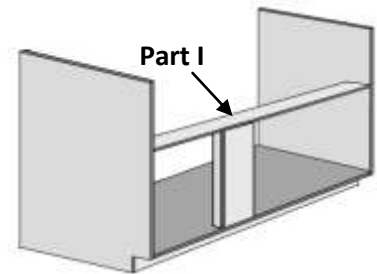

**STEP 13:** Place the unit in its back so that you can access the underside of the cabinet easily. Using three 50mm screws, secure Part O (1 screw) and Part M (2 screws) by drilling through Part B (Bottom Panel).

**STEP 14:** Locate the joined Part J and Part N. Place a small bead of wood glue in the dowel holes and secure the joined Part J and Part N to Part I using wood dowels.

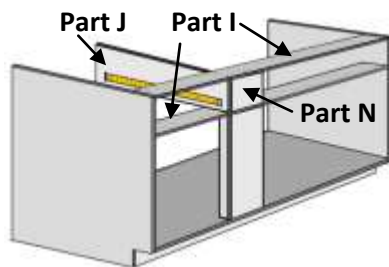

**STEP 15:** Locate the remaining Part I (Top Front Connecting Beam). Place the remaining Part I on top of the joined Part J and Part N. Secure Part I to Part J and Part N using three 50mm through the pre-drilled screw hole as well as on the sides using two 50mm screws on each side.

**STEP 16:** Locate Part C (Back Panel). IF YOU CHOOSE NOT TO INSTALL PART C, PROCEED TO STEP 16.

**NOTE:** Many RTA assemblers/installers choose not to use the back panel. Omitting the back panel doesn't compromise the strength of your cabinet.

**STEP 17:** To install the back panel, face the finished side of Part C towards the front of the cabinet and carefully slide it along the grooves at the rear of the unit. Be sure that the panel sits securely in the grooves along the base as well as the sides. You may need to give the panel a few gentle taps with your hand to seat the panel in the grooves.

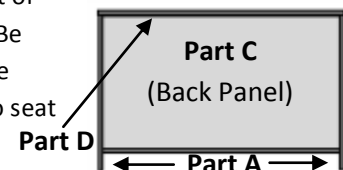

**STEP 18:** Locate Part D (Top Back Connecting Beam) and place it at the top of the unit over the back section just as you did with Part I in STEP 14 matching the pre-drilled holes in the midsection of Part J with those at the top of Part D. Secure Part D to Part J with two 50mm screws.



**NOTE:** IF YOU INSTALLED THE BACK PANEL, make sure to fit the grooves of Part D over the top edge of the back panel, framing the back panel.

**STEP 19:** Using four 50mm screws, secure Part D to each Part A as in STEP 14 for Part I.

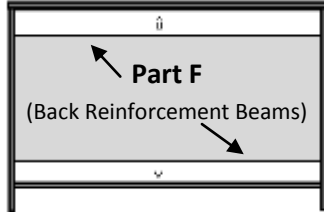

**STEP 20:** Locate the two Part Fs (Back Reinforcement Beam). These support beams secure the cabinet to the wall and (if you install the back panel) secures the back panel in place. Fit one Part F along the back of the cabinet at the top with the angled pre-drilled hole in the center pointed upwards and secure it using one of the 30mm screws. Use 50mm screws to attach Part F at the sides of Part A.

**STEP 21:** Repeat STEP 19 for the second Part F, securing it at the lower back section of the unit and ensuring the angled pre-drilled hole points downward.

**STEP 22:** Locate the Part E (Shelf) and install at the desired height using the four shelf pins.

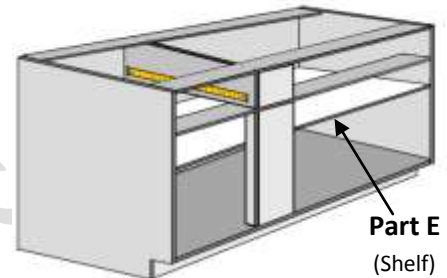

This completes the cabinet base assembly. For door and drawer assembly & instructions, set the cabinet base aside and please continue.



**DOOR ATTACHMENT**

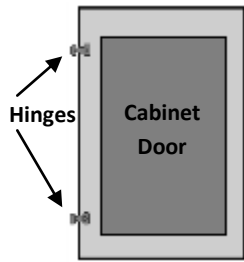

**STEP 1:** Locate the cabinet door and door hinges and place them on a sturdy work surface.

**STEP 2:** With the door facing downward, insert the body of the hinge into the pre-cored holes on the door and secure using the screws included in the hinge kit.

**NOTE:** Although the door comes pre-cored you should use a pocket level to align the hinges and make sure it is straight.

**STEP 3:** Decide in which direction you want the door to open then attach the door to the drawer/door side of the cabinet using the screws included in the hinge kit and aligning the hinges with the pre-drilled holes located on Part A or on Part O.

**STEP 4:** After setting the cabinet doors, they can be aligned (top to bottom, left to right) using the hinge position screws. The rear hinge position screw aligns top to bottom, the front position screw aligns the door from side to side.

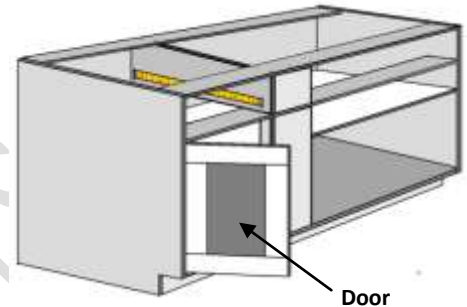

This concludes the door attachment instructions, for information on drawer assembly please continue.

**DRAWER ASSEMBLY**

Drawer assembly is simple yet precise. As all of the drawers use dovetail joining, it is important to be very careful during assembly and not to use unnecessary force as it could cause damage to the joiners.

Each drawer consists of 2 Drawer Sides (Part G), 2 Drawer Aprons (Part H – for soft closing drawers the rear and back drawer aprons will vary slightly – the rear apron will have a notch at the base of each side whereas the front apron has a straight base and will contain two pre-drilled holes in order to attach the Door Face), 1 Drawer Bottom (Part K), and the Drawer Front (not shown in the exploded view of the part list).

**STEP 1:** Collect your tools. For this project you will need:

- Power Drill with Phillips screwdriver tip
- Wood glue
- Rubber mallet
- 2 x 4 piece of scrap wood

**STEP 2:** For each drawer, locate 2 Drawer Sides (Part G), 2 Drawer Aprons (Part H – one notched as well as one straight bottom with pre-drilled holes), 1 Drawer Bottom (Part K), and the Drawer Front and set them on a secure work surface bottom groove side facing upward.

**STEP 3:** Set aside one of the drawer aprons (Part H) and one of the drawer sides (Part G). Place a small bead of wood glue between the dovetail joiners on one side of the front drawer apron (Part H).

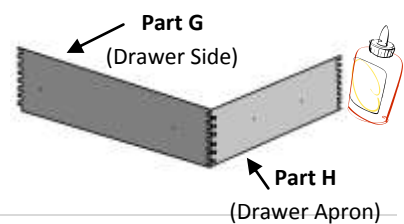



**STEP 4:** Align the drawer side (Part G) with the glued side of the front drawer apron (Part H), ensuring the grooves at the base of each piece align, and that the dovetail joiners align. Tap gently with the rubber mallet.

**PRO TIP:** To fit the pieces together and avoid damage to the box and joiners, use the scrap 2 x 4 by placing it over the dovetail joint. Tap the mallet firmly but carefully. The 2 x 4 distributes the pressure of the mallet evenly and also keeps the mallet from leaving impressions in the wood. *Remember – Although dovetail makes a very secure joining the dovetail tongues are vulnerable to damage until the sides are assembled, be careful and try not to force pieces together.*

**STEP 5:** Locate Part K (Drawer Bottom). Slide the drawer bottom into place along the grooves.

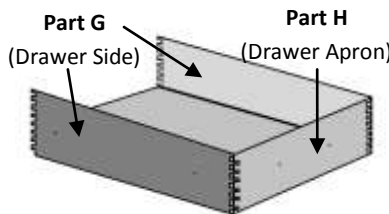

**STEP 6:** Place a small bead of wood glue between the dovetail joiners on opposite side of the front drawer apron (Part H) already joined to the drawer side (Part G). Take the other drawer side (Part G) and slide it into place, aligning it with the glued dovetail joiners and the drawer base. Tap gently with the rubber mallet as described in STEP 4 and as listed in the above *PRO TIP*.

**STEP 7:** Locate Part G (the back Drawer Side). Apply small beads of wood glue on both dovetail joiner sides. Align the back drawer apron (Part H) to the drawer sides (Part G) and drawer base, gently tapping it into place with the mallet. Repeat the instructions listed in the above *PRO TIP*. Repeat for all drawers STEP 2 – STEP 7 for all drawers.

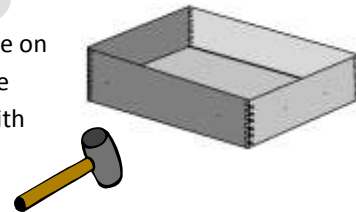

**STEP 8:** Locate the Drawer Box Segment of the drawer glides set aside earlier during the cabinet base assembly.

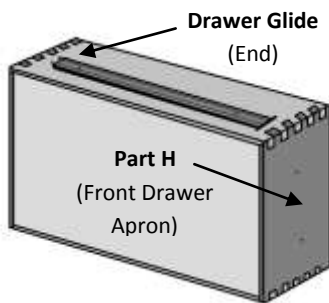

**STEP 9:** Placing the assembled drawer box on its side, positioning the drawer box segment of the drawer glides so that the break end faces the front of the box and the pinched end faces the rear. Be sure to align the pre-drilled holes on the drawer sides with holes on the drawer slide. Secure using the 12mm slide screws. Repeat for each side of the drawer.

**STEP 10:** Attaching Drawer Fronts: Use a piece of scribe molding as a spacer to align the fronts then attach from the back, inside the drawer, using 30mm screws. Clamps come in handy to hold the pieces in place during drilling. **Keep in mind you won't necessarily attach the drawer fronts to the drawer aprons at the pre-drilled holes. Each style is different. As a rule, ALWAYS attach aprons to the "meat" of the drawer front to avoid drawer front damage.**

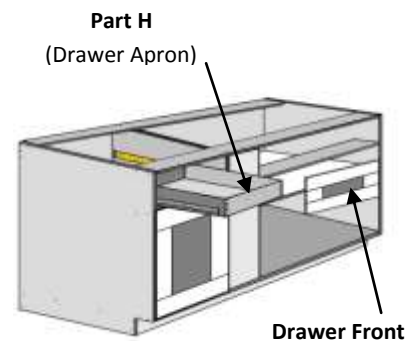

**NOTE:** When attaching handles, be sure not to over-tighten screws as it could damage the front. You may wish to attach hardware to the "meat" of the drawer front (such as the frame on a shaker-style cabinet).



**FINISHING UP**

Congratulations, you have just assembled your Blind Corner Base Cabinet! To finish up, place the adhesive plastic stoppers at the corners of the drawers and doors to keep them from banging upon closing.

Before installing, take a moment to re-inspect your work a final time, looking for any screws that could be tightened or hinges that could be adjusted slightly.

DOMAIN CABINETS DIRECT